



2022



Margaroli[®]
1949

100% made in Italy

AZIENDA

Molta acqua è passata dentro i nostri tubi! Sorta nel 1949, fondata da Egidio Margaroli, l'azienda Margaroli è oggi una realtà industriale moderna, basata su processi produttivi integrati, controllo completo del prodotto e rispetto dell'ambiente. La produzione, iniziata con la lavorazione della lastra di ottone e di rame, nel corso degli anni è andata via via specializzandosi verso quella del tubo e della barra di ottone per idrosanitaria e rubinetteria, attività che ci colloca attualmente tra le aziende leader in Italia. L'azienda propone prodotti in grande serie, quanto su specifiche esigenze della clientela. Tuttavia la capacità di produrre su larga scala non fa perdere di vista l'elemento qualità e l'elemento servizio. Negli ultimi anni oltre alle certificazioni internazionali di prodotto e alle certificazioni di qualità UNI EN ISO 9001, già conseguite da oltre due decenni, l'azienda ha ottenuto dall'Istituto per la Tutela dei Produttori Italiani, (con registrazione N°439.070.V) il certificato di 100% MADE IN ITALY.



Stabilimento 1:
Scaldasviette
e accessori bagno



Stabilimento 2:
MargaroliHome /
Heataly



Uffici e Stabilimento 1:
Invorio (NO) Italy

★ ★ ★ ★ ★
70
• SINCE 1949 •

COMPANY

A lot of water has passed through our pipes!
Founded by Egidio Margaroli in 1949, the present day company Margaroli is a modern industrial enterprise, established on the use of integrated production processes, complete control of the manufactured products and awareness of the environment. The production, which began with the processing of brass and copper plates, over the years has expanded into the specialty of manufacture of products from brass pipe, used in the production of sanitary and plumbing fixtures, this practice has allowed us to be one of the leading companies in Italy. The company offers production in large quantities, as well as taking into account specific customer requirements. Production in large quantities, however, does not affect the high product and service quality. Recently, the company has obtained the 100% MADE IN ITALY Certificate (registration N° 439.070.V) issued by the Institute for the Protection of Italian Manufacturers; in addition to the international product certificates and UNI EN ISO 9001 Quality Management Certificates, which the company has possessed for over ten years.

КОМПАНИЯ

Много воды протекло по нашим трубам!
Основанная в 1949 году эджидио маргароли, сегодня компания margaroli - это современное промышленное предприятие, основанное на использовании интегрированных производственных процессов, комплексного контроля выпускаемой продукции и уважении к окружающей среде. Производство, которое началось с обработки листовой латуни и меди, с годами переросло в специализацию изготовления изделий из латунных труб, используемых в производстве запорной арматуры и смесителей, деятельность, которая позволила войти в число ведущих компаний италии. Компания реализует продукцию в больших количествах, исходя из конкретных потребностей заказчика. Однако способность производить в больших масштабах не влияет на высокий уровень качества и обслуживания. В дополнение к международным сертификатам продукции и сертификатам соответствия системы качества uni en iso 9001, насчитываемым уже более десяти лет, недавно компания получила сертификат 100% сделано в италии (регистрационный номер n°439.070.V) от института по защите итальянских производителей.



CERTIFICATION

CERTIFICAZIONI DELL'AZIENDA
CERTIFICATIONS
СЕРТИФИКАТЫ



CERTIFICAZIONI DI PRODOTTO
CERTIFICATIONS
СЕРТИФИКАТЫ



Ukr SEPRO



Worldwide Market Access



100% MADE IN ITALY



CARTELLINI IDENTIFICATIVI 100% MADE IN ITALY
Contraddistinguono il vero prodotto originale
Margaroli®. Sono allegati ad ogni singolo articolo di
produzione Margaroli®, Margarolihome® e Heataly®.
COUPONS CERTIFICATING 100% MADE IN ITALY

100% MADE IN ITALY IDENTIFICATION TAGS
**They distinguish the true original Margaroli®
product. They will be joint to every singular article
of Margaroli®, Margarolihome® and Heataly®
production.**

НОВЫЕ СЕРТИФИКАЦИОННЫЕ КУПОНЫ,
ИДЕНТИФИЦИРУЮЩИЕ ЗНАК
«100% СДЕЛАНО В ИТАЛИИ»
Обозначают оригинальность происхождения
продукции Margaroli®. Прилагаются к каждому
отдельному изделию Margaroli®,
Margarolihome® и Heataly®.

1



I SEGNI DISTINTIVI DI UN VERO PRODOTTO
MARGAROLI® 100% MADE IN ITALY SONO:
L'adesivo olografico dell'istituto per la tutela dei
produttori italiani, con il codice di registrazione
dell'azienda (IT01.IT/439.070.V) verificabile sul sito:
http://www.madeinitalycert.it/rintracciabilita_it.php

**DISTINCTIVE MARKS FOR TRUE MARGAROLI®
100% MADE IN ITALY PRODUCT ARE:**
**The holographic label of institute for the safeguard
of italian manufacturer, provided with the company
registrated code (IT01.IT/439.070.V), you can
verify in the website:**
http://www.madeinitalycert.it/rintracciabilita_it.php

ОПОЗНАВАТЕЛЬНЫЕ ЗНАКИ ОРИГИНАЛЬНОЙ
ПРОДУКЦИИ MARGAROLI® «100% СДЕЛАНО В
ИТАЛИИ»:
Голографическая марка института по защите
итальянских производителей с регистрационным
номером компании (IT01.IT/439.070.V), который
можно проверить на сайте: [http://www.
madeinitalycert.it/rintracciabilita_it.php](http://www.madeinitalycert.it/rintracciabilita_it.php)

2



Numero di serie progressivo (posizionato in alto a destra del cartellino identificativo) verificabile semplicemente inviando una mail all'indirizzo rintracciabilita_prodotto@margaroli.com, dove ogni singolo cliente può verificare, l'originalità del prodotto, lotto e data di produzione.

Serial progressive number (placed on the right top of the certificating coupon) you can verify simply e-mailing to: rintracciabilita_prodotto@margaroli.com, where every customer can check originality, lot and production date of the product.

Прогрессивный серийный номер (находится в правом верхнем углу идентификационного купона), который можно проверить, отправив электронный запрос на адрес rintracciabilita_prodotto@margaroli.com, где каждый клиент может проверить оригинальность изделия, номер партии и дату производства.

3



Adesivo rintracciabilità posizionato nella parte inferiore di ogni singolo articolo (di fianco all'adesivo con i dati di targa).

Traceability stick placed in the bottom part of every singular article (close to the serial plate label).

Идентификационная марка, расположенная в нижней части каждой отдельной модели (рядом с серийными данными).

FINITURE



FINITURE SCALDASALVIETTE HEATED TOWEL RAIL FINISHINGS ПОКРЫТИЯ ДЛЯ ПОЛОТЕНЦЕСУШИТЕЛЕЙ



CROMO
CHROME
ХРОМ



CROMO SATINATO
SATIN CHROME
ХРОМ МАТОВЫЙ



CROMO SPAZZOLATO
BRUSHED CHROME
ХРОМ ШЛИФОВАННЫЙ



NICKEL SATINATO
SATIN NICKEL
НИКЕЛЬ МАТОВЫЙ



CROMO NERO
CHROME BLACK
ХРОМ ЧЕРНЫЙ



NICKEL LUCIDO
BRIGHT NICKEL
НИКЕЛЬ ПОЛИРОВАННЫЙ



BRONZO/OTTONE ANTICO
BRONZE/OLD BRASS
БРОНЗА / АНТИЧНАЯ ЛАТУНЬ



RAME
OLD COPPER
МЕДЬ



OLIO BRUCIATO
(TUSCAN BRASS)
OIL RUBBED BRONZE
БРОНЗА ЖЖЕНАЯ



ORO
GOLD
ЗОЛОТО



ORO SPAZZOLATO
BRUSHED GOLD
ЗОЛОТО ШЛИФОВАННОЕ



OTTONATO
POLISH BRASS
ЛАТУНЬ



ORO INCALUX
ENGLISH GOLD
ЗОЛОТО АНГЛИЙСКОЕ



BRONZO OPACO
MAT OLD BRASS
БРОНЗА МАТОВЫЙ



NICKEL SPAZZOLATO
BRUSHED NICKEL
НИКЕЛЬ ШЛИФОВАННЫЙ



CHAMPAGNE
ШАМПАНСКОЕ



BIANCO RAL 9010
WHITE_RAL 9010
БЕЛЫЙ RAL 9010



NERO OPACO
MATT BLACK
ЧЕРНЫЙ МАТОВЫЙ



NERO LUCIDO
POLISH BLACK
ЧЕРНЫЙ ПОЛИРОВАННЫЙ



BIANCO/CROMO
WHITE/CHROME
БЕЛЫЙ/ХРОМ



CROMO/ORO
CHROME/GOLD
ХРОМ/ЗОЛОТО



BIANCO/ORO
WHITE/GOLD
БЕЛЫЙ/ЗОЛОТО

FINITURE EXTRA



EXTRA FINISHING

Disponibili solo per:

Available only for:

Доступно только для:

Art. 7-464 / 9-203 / 9-204 / 9-213

8-564 / 9-503 / 9-504 / 9-513

(RADIATORE INTERNO)



BIANCO LUCIDO
POLISH WHITE
БЕЛЫЙ ПОЛИРОВАННЫЙ

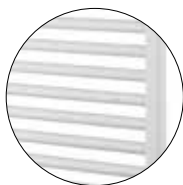

BIANCO PERLATO
PEARL WHITE
ЖЕМЧУЖНО БЕЛЫЙ



NERO TEXTURIZZATO
POLISH BLACK
ЧЕРНЫЙ ПОЛИРОВАННЫЙ

AROMATERAPIA

L'aromaterapia è un trattamento naturale molto apprezzato che prevede l'impiego di essenze che donano un'intensa sensazione di benessere. L'aromaterapia è tanto preventiva quanto curativa; essa apporta, infatti, benefici sia a livello mentale che fisico. I profumi fanno parte della nostra vita ed ognuno di noi li percepisce in maniera del tutto personale. Nei nostri nuovi porta essenze da apporre agli scaldasalviette ed ai radiatori.

Aromatherapy is a natural treatment of ancient origin, which is greatly appreciated and performed with the use of essences that give an 'intense feeling of well-being'. Aromatherapy is both preventive and curative, it brings benefits both mentally and physically, the scents are part of our lives and each of us perceives them in a personal way. To be placed into our new essence containers combined with the heated towel rails / radiators.





Ароматерапия - это природный метод лечения, пользующийся популярностью и заключающийся в использовании эфирных масел, которые дарят ощущение комфорта. Ароматерапия обладает профилактическими и целительными свойствами, улучшает моральное и физическое состояние человека. Запахи являются частью нашей жизни, и каждый из нас воспринимает их по-своему. Предлагаем специальный ассортимент ароматных гелей: Эвкалипт, Зеленый чай, Морской, Хлорофилл и Цитрусовый, - для размещения в наших ёмкостях для ароматизированных масел.

24K GOLD

La doratura galvanica nasce in Italia nel 1802 presso l'università di Pavia; Luigi Valentino Brugnatelli conduce il primo esperimento di doratura galvanica utilizzando la neo-nata pila galvanica, messa a punto da Alessandro Volta del quale Brugnatelli era amico e collaboratore. Si tratta di un procedimento galvanico, e come tale è adatto solo all'utilizzo su metalli. Un elemento metallico viene immerso in un bagno galvanico e attraversato da correnti elettriche. Le correnti passando da un elettrodo in oro all'altro elettrodo (l'oggetto immerso) apportano particelle di materiale dorato sull'oggetto immerso. Su tutti i prodotti venduti da MARGAROLI viene eseguito questo antico procedimento e con il trattamento di doratura "OROLUX" in cui viene impiegato oro a 24 Kt.

The gold plating finishing was created in Italy in 1802 at the University of Pavia. Luigi Valentino Brugnatelli leads the first experiment for galvanic gilding using the newly-invented galvanic battery, developed by Alessandro Volta whose Brugnatelli was a friend and collaborator. It is a galvanic process, and as such is only suitable for use on metals. A metal element is immersed in a galvanic bath and traversed by electric currents. The currents passing from a gold electrode to the other electrode (the object immersed) provide particles of material on the object to be gilded. All products sold by MARGAROLI are executed with this ancient procedure and the treatment of gilding "OROLUX" using gold 24Kt.



Гальваническая позолота была изобретена в Италии в Университете Павии в 1802 году. Луиджи Валентино Бруниятелли провёл первый эксперимент с гальванической позолотой, используя новую гальваническую батарею, созданную его другом и сотрудником Александром Вольтом. Гальванический процесс может быть применен только в отношении металлов. Металлический элемент погружают в гальваническую ванну и проводят электрический ток. Электрический ток при прохождении от золотого электрода к другому электроду (погруженной детали) переносит частицы материала на данную деталь. Для всей продукции MARGAROLI применяется этот старинный метод позолоты "OROLUX" с использованием золота 24 карат.





Gli scaldasalviette ad acqua sono completi di rubinetti, per collegamento ai tubi in ferro, di kit fissaggio a parete e di valvole a sfiato.

Hydronic heated towel rails are provided with taps for iron pipes connections, with accessories kit to be fixed to the wall and with breathing vent valve.

Водяные полотенцесушители комплектуются вентилями для подключения к системе, реализованной из железной трубы, комплектом настенных креплений и воздушными клапанами.



Gli scaldasalviette elettrici vengono forniti completi di scatola interruttore (BOX) montato sulla destra ** (a richiesta il box può essere montato sulla sinistra).

Electric heated towel rails are equipped with the switch box (BOX) on the right side ** (on request, it can be assembled on the left side).

Электрические полотенцесушители поставляются в комплекте с коробкой выключателя (BOX), установленной справа ** (под заказ можно установить ее слева).



DIAMANTE ART. 740



Scaldasalviette fisso
componibile con tubo
a sezione quadra.

**Fixed modular towel warmer
with square section tube.**

Стационарный квадратный
олотенцесушитель.

VERSIONE ACQUA
HYDRONIC VERSION

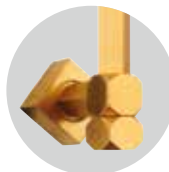

VERSIONE ELETTRICA
ELECTRIC VERSION





QUADRI ART. 810/5



Scaldasalviette fisso con tubo a sezione quadra.
Fixed towel warmer with square section tube.
Стационарный квадратный полотенцесушитель.



Versione idraulica disponibile.
Available hydronic version.
Доступна гидравлическая версия.

SOLE ART. 622



Composizione di barre riscaldate in ottone con struttura ad incasso.

Set of heated brass bars with built-in structure.

Набор обогреваемых латунных стержней со встроенной конструкцией.





LUCE ART. 521/G



Asta godronata, scaldante
in tubo d. 25mm.

**Horizontal heating rod
(d.25mm), with knurling on
the surface of the tube.**

Горизонтальный
нагревательный стержень
(d.25мм), с накаткой на
поверхности трубки.



SERENO ART. 621/G



Asta godronata scaldante
in tubo d. 32mm.

**Horizontal heating rod
(d.32mm), with knurling on
the surface of the tube.**

Горизонтальный
нагревательный стержень
(d.32мм), с накаткой на
поверхности трубки.

ON/OFF SWITCH
ON REQUEST







PANORAMA ART. 671



Scaldasalviette fisso.

Electric heated towel rail.

Модульный стационарный электрический.

ON/OFF SWITCH
ON REQUEST



PANORAMA ART. 682



Scaldasalviette fisso componibile a sezione rettangolare.

Fixed rectangular modular towel warmer.

Стационарный модульный полотенцесушитель прямоугольного сечения.

ON/OFF SWITCH
ON REQUEST







ARMONIA ART. 9-442/C



Scaldasalviette fisso
componibile in tubo di
ottone cordonato
**Fixed modular towel
warmer in corded brass tube.**
Стационарный модульный
полотенцесушитель в
латунной трубке
со шнуром.



Versione elettrica disponibile.
Available electric operation.
Доступна с электрическим
приводом.

ARMONIA ART. 9-512/C



Scaldasalviette fisso
componibile in tubo di
ottone cordonato

**Fixed modular towel
warmer in corded brass tube.**

Стационарный модульный
полотенцесушитель в
латунной трубке
со шнуром.



Versione idraulica disponibile.

Available hydronic version.

Доступна гидравлическая
версия.



ART. 740

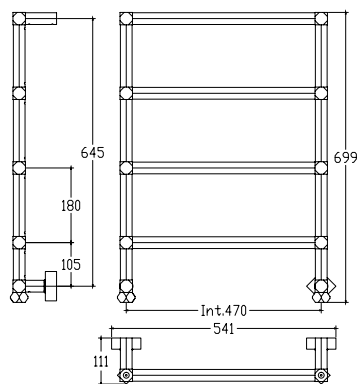

ART. 622

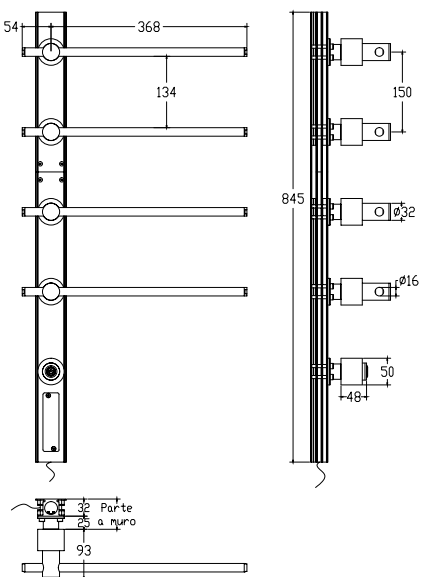

ART. 810/5

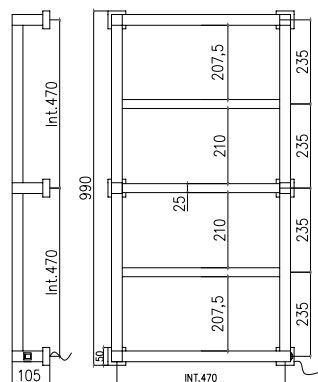

ART. 521/G

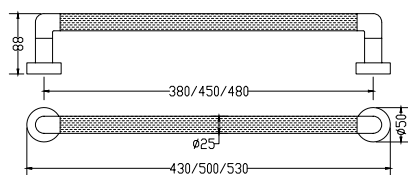

ART. 621/G

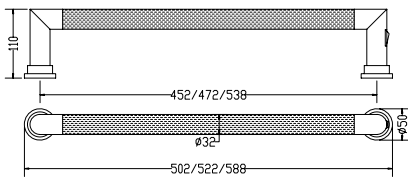

ART. 9-442/C

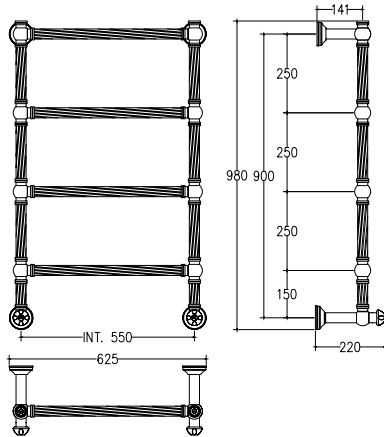

ART. 682

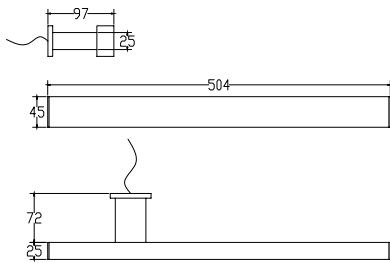

ART. 9-512/C

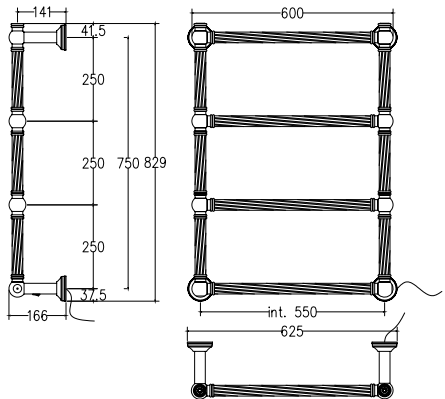

ART. 671

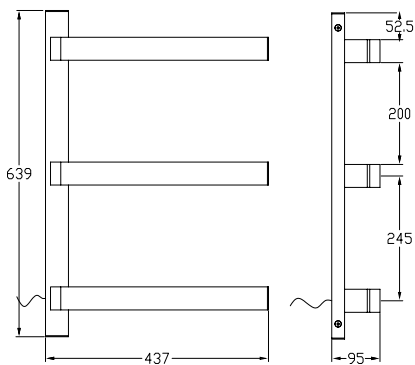





MARGAROLI srl

Sede legale e stabilimento: Via per Arona, 29 - 28024 Gozzano (NO) Italy
Uffici e stabilimento: Via Barro 64/66 (Zona Ind.) - 28045 Inverio (NO) Italy

Tel. +39 0322.254110 r.a. - Fax +39 0322.254101
www.margaroli.com - info@margaroli.com

NEW GENE RATION 21



SERE NO



631

Consolle in ottone riscaldata elettricamente.
Le dimensioni possono essere modificate in
base alle esigenze del cliente. Disponibile in
oltre 20 finiture.

Electrically heated brass console. The size
can be changed according to the customer's
needs. Available in over 20 finishes.



La struttura è pensata anche per accogliere
il ripiano (top) su cui appoggiare il lavabo.

The structure is also designed to
accommodate the shelf (top) on which
to place the washbasin.

SCAN temperatura
Temperature SCAN



AR MO NIA

9-631

Consolle in ottone dal design classico riscaldata elettricamente. Disponibile in oltre 20 finiture. La struttura è pensata anche per accogliere il ripiano (top) su cui appoggiare il lavabo.

Console made in brass electrically heated with classic design. Available in over 20 finishes. The structure is also designed to accommodate the shelf (top) on which to place the washbasin.





PANO RA MA

671

Lo scaldasalviette necessita di un solo punto luce di collegamento elettrico per riscaldare tutta la struttura. Questo permette di evitare interventi di muratura ed avere in bagno un prodotto dal design moderno. Il materiale impiegato, come sempre, è l'ottone e quindi anche questo modello è disponibile in oltre 20 finiture.

The towel warmer needs only one electrical connection point to heat the entire structure. This allows you to avoid masonry work and have a modern design product in the bathroom. The material used, as always, is brass and therefore this model is also available in over 20 finishes.







Margaroli

100% made in Italy

PANO RA MA



RA DIA TORI

“MARGAROLI HOME” presenta le novità per la stagione 2021. I suoi radiatori in alluminio sono personalizzabili in composizioni, colori, dimensioni (da H.600mm x L.100mm fino a H.2000mm x L.1000mm) e disponibili in versione idraulica, elettrica o combinata.

MARGAROLI HOME presents the news for the 2021 season. Its aluminum radiators are customizable in compositions, colors, dimensions (from H.600mm x W.100mm up to H.2000mm x W.1000mm) and available in hydraulic, electric or combined version.



COR NER

Radiatore che permette di sfruttare gli **angoli esterni** spesso inutilizzati del vostro ambiente. Composizione e dimensioni personalizzabili.

Radiator that allows to take advantage of the often unused **external corners** of your home environment. Customizable composition and dimensions.



COR NER

Radiatore che permette di sfruttare gli **angoli interni** spesso inutilizzati del vostro ambiente. Composizione e dimensioni personalizzabili.

Radiator that allows to take advantage of the often unused **internal corners** of your home environment. Customizable composition and dimensions.



COVER LINE



Margarolihome[®]
100% made in Italy





LI NEE



MARGAROLI HOME aggiunge nuovi colori RAL alle sue collezioni.

MARGAROLI HOME adds new RAL colors to its collections.



RAL 7047

RAL 7044

RAL 7042

RAL 7030

RAL 5024

RAL 5014

LI NEE

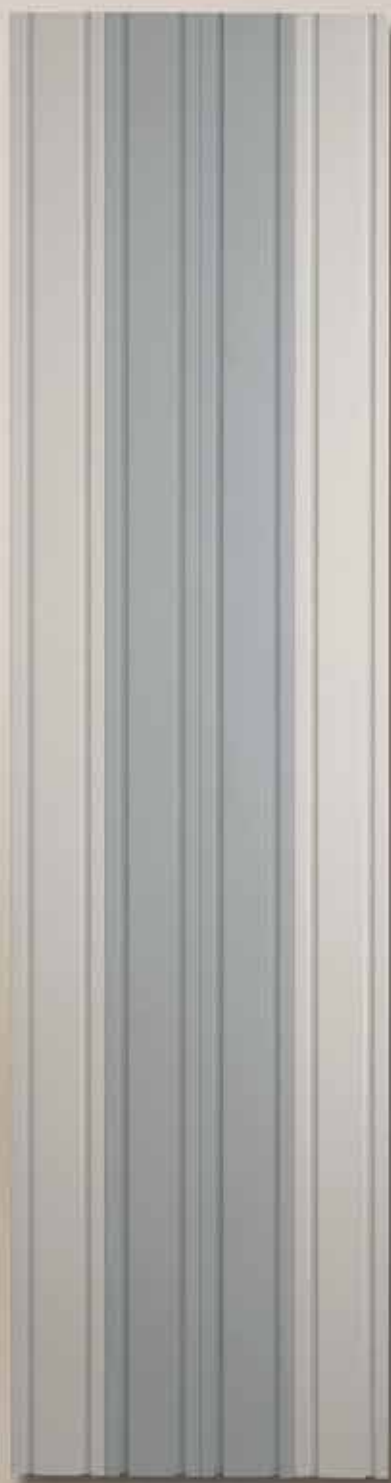



Margarolihome[®]
100% made in Italy

ORTA

Radiatore con abbinamento di colori a scelta tra metallici o verniciati RAL.

New collection with combination of colors of your choice, metals or embossed RAL.









✦ ORTA

Margarolihome®
100% made in Italy

NEW GENERATION RATON 21

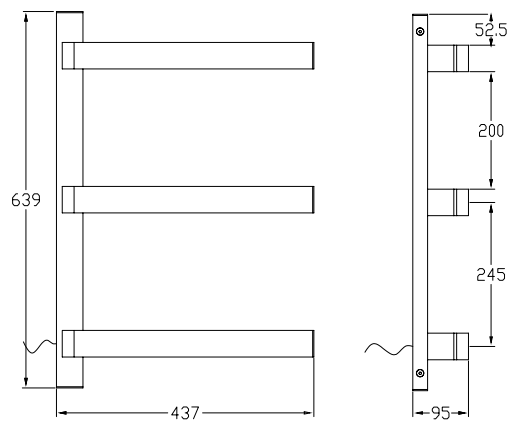

671

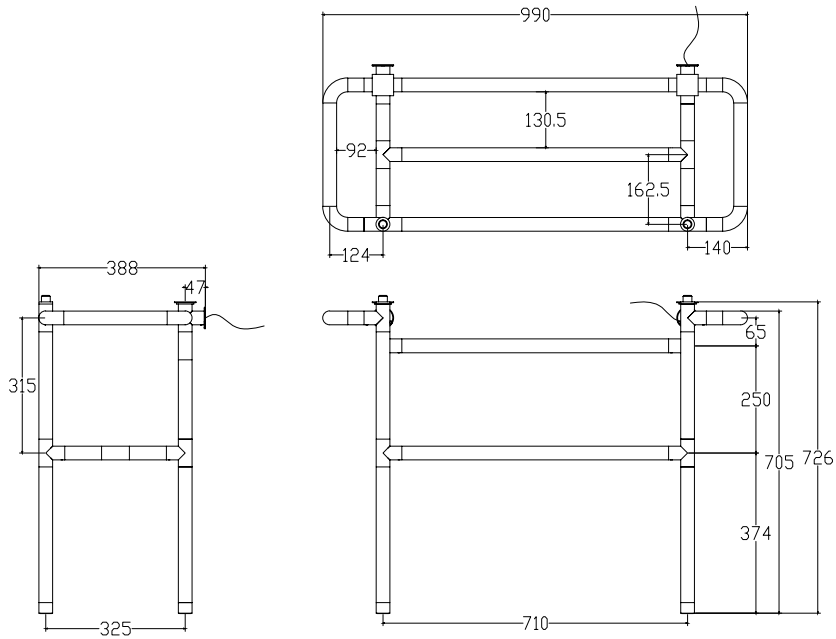

631

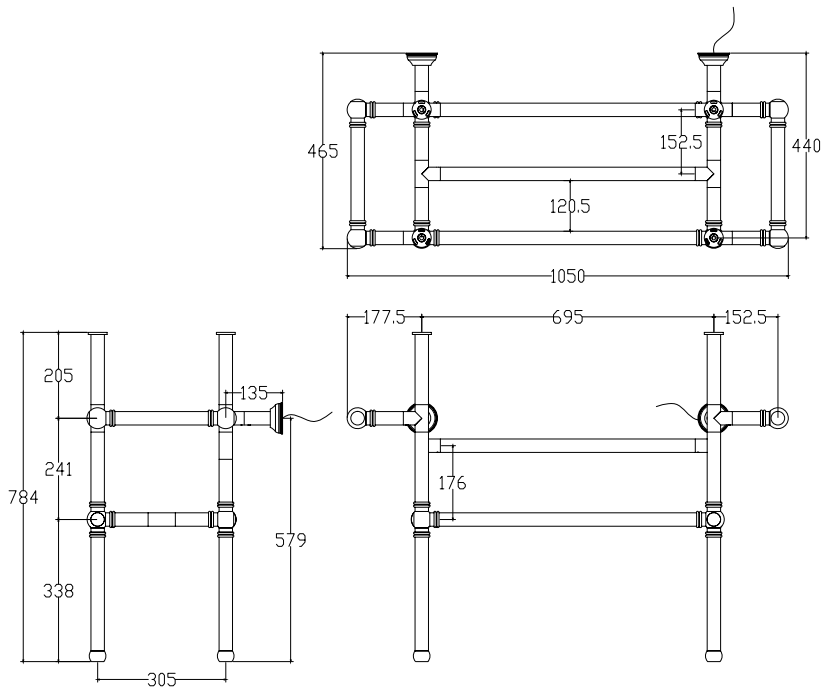

9-631

NEW GENERATION 21

ELEMENTO SCALDANTE
MODULARE BASE
BASE MODULE
HEATING ELEMENT

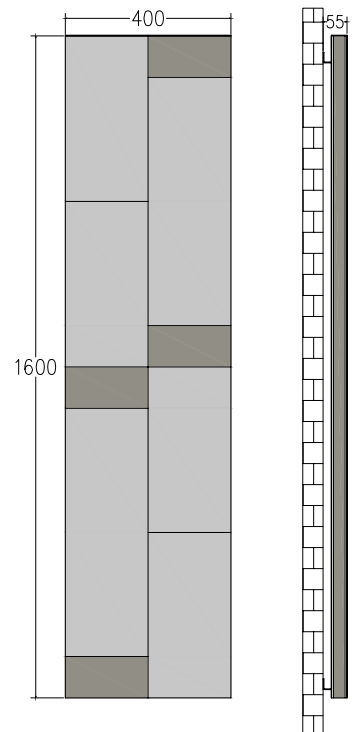
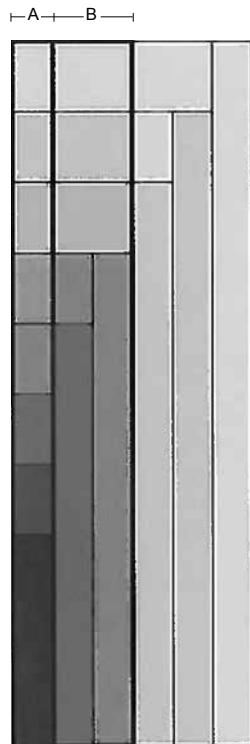

ORTA casa / home

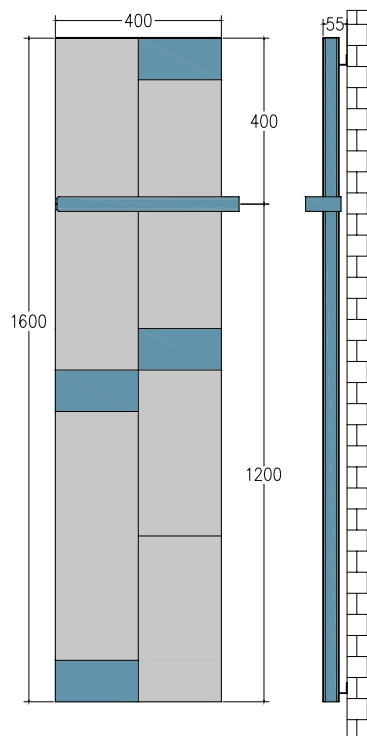

ORTA bagno / bathroom

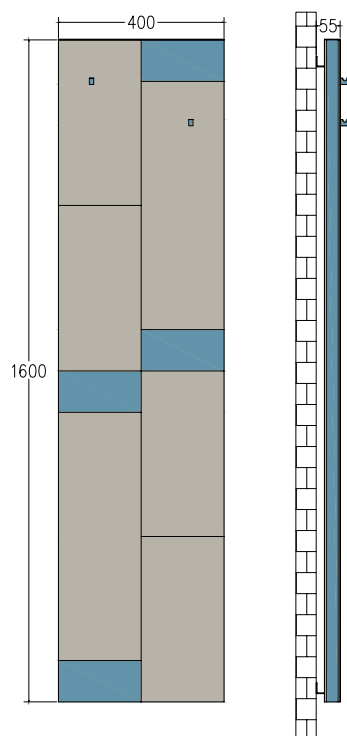

ORTA appendini / hangers

NEW GENERATION RATON 21

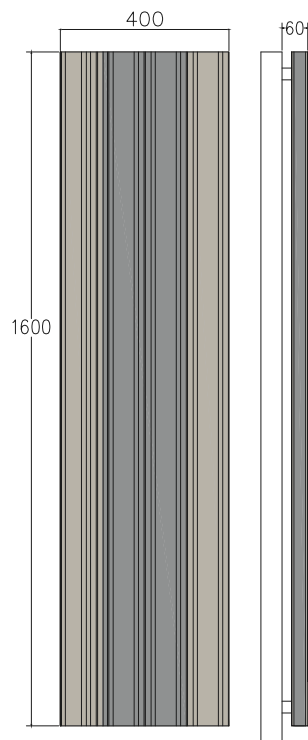

LINEE

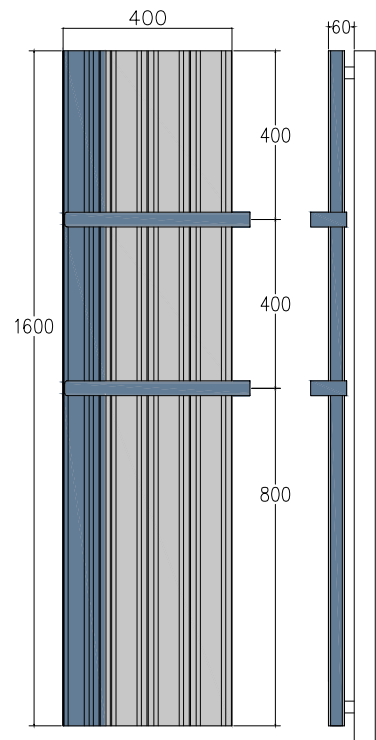

LINEE due mensole / two shelves

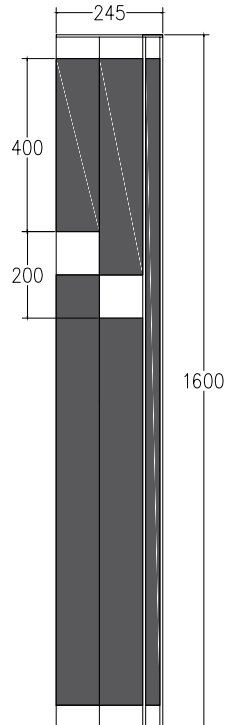
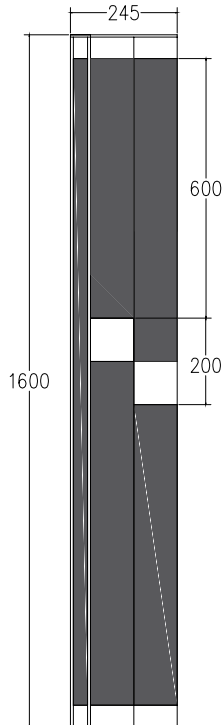
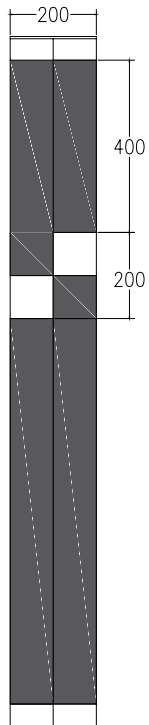
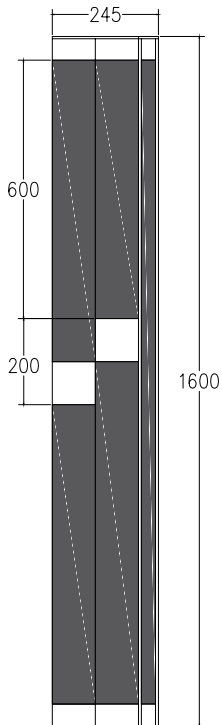
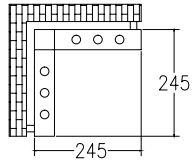
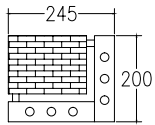

CORNER esterno / external

CORNER interno / internal



MARGAROLI srl

Sede legale e stabilimento: Via per Arona, 29 - 28024 Gozzano (NO) Italy
Uffici e stabilimento: Via Barro 64/66 (Zona Ind.) - 28045 Inverio (NO) Italy

Tel. +39 0322.254110 r.a. - Fax +39 0322.254101
www.margaroli.com - info@margaroli.com